

**KITPLANES FOR AFRICA**  
**www.saplanes.co.za**  
**P.O.Box 326**  
**KOMATIPOORT**  
**1340**  
**South Africa**

**Rick Burrough 082 410032      Stefan Coetzee 082 6018970**  
**info@saplanes.co.za**

## **SERVICE BULLETIN**

**AIRCRAFT EFFECTED:** All models  
**BULLETIN NUMBER:** SB019  
**ORIGINAL ISSUE DATE:** 23-11-05  
**REVISION DATE:** 18-11-08  
**SUBJECT:** Control rod-end failure  
**APPLICABILITY:** All KFA aircraft  
**COMPLIANCE:** Mandatory

**Problem:** There was a recorded case of a Bushbaby loosing aileron control due to a rod-end bearing failure.

The failure occurred in the male bearing between the FBC-1 bell crank and the FCS-A control stick housing.

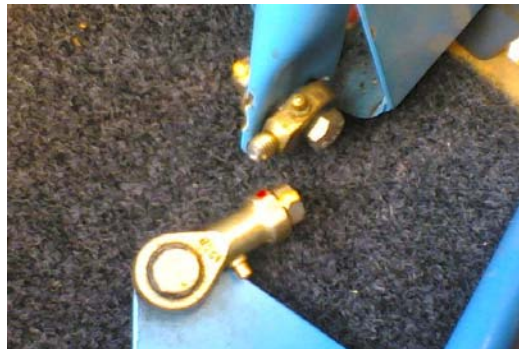

The eyes of the two rod-end bearings allow the control stick to move freely forward and aft within a limited range.

If this range is exceeded the bearings will be subjected to a twisting load.

The thread on the male rod-end bearing is the weakest link in the assembly and will fail first.

The amount of control stick travel is controlled by the two stop clamps, one either side of the FEV-1 bush on the FCT-7 elevator pushrod.

**Solution:** Inspect the two rod-ends for binding by moving the stick full forward and aft, the bearings must have slight free play at either end of the elevator travel.

If there is no free play, replace the male rod-end bearing, install and rig the assembly according to the procedure below.

If there is any doubt about the condition of the bearing, replace it!

- When rigging the elevator travel, inspect the two rod-ends for binding by moving the stick full forward and aft, the bearings must have slight free play when the stop clamps contact the FEV-1 bush.
- If there is no free play, follow the procedure below to obtain full elevator travel whilst still having play on the rod-end bearings.
- The N006 locknut **MUST** be installed and set. It is not acceptable to have the rod-end bearings rotate about the thread after rigging.
- If no lock nut was installed the male and female bearing **MUST both** be replaced.

## PROCEDURE:

Please see figure below for reference

1. Set the hose clamp limit stops on the elevator tube for the desired up and down elevator, normally 15° down & 25° up. If more up elevator is required then reduce the down travel

**NOTE :** The rotation in the rod-end bearing allows for a total elevator travel of 40°.

2. Thread the N006 locknut onto the FC-2 male rod-end bearing, thread the FC-1 and FC-2 bearings together.
3. Install the assembled bearings in position, replace the B0625 bolt with a 6x25 cap screw and fit an M6 spring washer between the bearing and FBC-1. The washer acts as a spacer.
4. If more play is needed on the bearings, an additional M6 spring washer can be installed between the rod-end and FCS-A control stick housing.
5. Move the stick full back until the stop is engaged. Rotate the rod-end bearing forward and lock the lock nut. Move the stick fully forward and check that there is still free play in the rod-end.
6. When rigging is complete, mark the FC-2 rod-end thread for future inspection to ensure the locknut remains set.
7. Record the replacement/ inspection in the logbook and have an AP inspect and sign out the work.

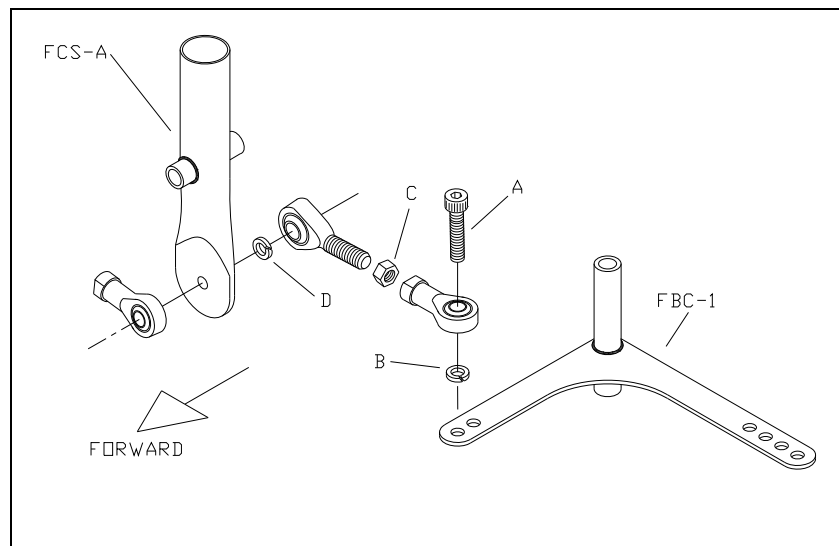

- A Cap screw M6 x 25
- B M6 spring washer
- C M6 lock nut (must be installed)
- D M6 spring washer. Optional if rod-end fouls FCS-A