

APPENDIX AL

KITPLANES FOR AFRICA

AMO: M660



AIRCRAFT AERO-MUTI MANUAL

NOTE:	Please read through the entire Aeromuti Manual and the Covering Manual before covering.
--------------	---

CONTENTS

PART 1	PRODUCT INFORMATION	A5
PART 2	OVERVIEW OF COVERING SEQUENCE	A6
PART 3	GENERAL HINTS AND TIPS	A13
PART 4	PRACTISE SECTION – RUDDER	A15

LIST OF EFFECTIVE PAGES

PAGE	DATE	REVISION STATUS
A1	09/2008	Revision D
A2	09/2008	Revision D
A3	09/2008	Revision D
A4	09/2008	Revision D
A5	09/2008	Revision D
A6	09/2008	Revision D
A7	09/2008	Revision D
A8	09/2008	Revision D
A9	09/2008	Revision D
A10	09/2008	Revision D
A11	09/2008	Revision D
A12	09/2008	Revision D
A13	09/2008	Revision D
A14	09/2008	Revision D
A15	09/2008	Revision D
A16	09/2008	Revision D
A17	09/2008	Revision D

AMMENDMENT RECORD

AMMENDMENT NO	PAGE	RECORDED BY
Revision D	A1	RM Burrough
Revision D	A2	RM Burrough
Revision D	A3	RM Burrough
Revision D	A4	RM Burrough
Revision D	A5	RM Burrough
Revision D	A6	RM Burrough
Revision D	A7	RM Burrough
Revision D	A8	RM Burrough
Revision D	A9	RM Burrough
Revision D	A10	RM Burrough
Revision D	A11	RM Burrough
Revision D	A12	RM Burrough
Revision D	A13	RM Burrough
Revision D	A14	RM Burrough
Revision D	A15	RM Burrough
Revision D	A16	RM Burrough
Revision D	A17	RM Burrough

PART 1: PRODUCT INFORMATION

The Aeromuti fabric covering process was developed around South African manufactured products and works as well as any equivalent imported product. All components (fabric, cement, sealer and solvents) were developed to have no adverse effects upon each other. It is important not to substitute materials, cement, sealer or use other thinners or solvents than those supplied 'in the kit.

The following are the products in the Aeromuti covering system:

2.2 OZ FABRIC, CC-4A

The flight proven polyester covering material supplied is of very high quality and strength. It utilizes the natural characteristics of a heat stretched thermoplastic synthetic filaments to return to the original shorter length when reheated. Polyester has all the well-balanced characteristics needed for an aircraft fabric. If properly applied and UV-protected the polyester has an indefinite life.

To match the unique characteristics of polyester, a durable cement and fabric sealer combination was developed using a low acid, nitro cellulose base.

FABRIC SURFACE TAPES, CC-1A

Surface or finishing tape is polyester fabric cut in to various widths and different lengths. The tapes are used to cover seams and to provide an extra layer of cloth over areas that need reinforcement. The 2" pinked tapes are pre-shrunk to 250°F and a higher heat 300°F must be applied to further shrink the tapes around curves. The straight cut tapes are not pre-shrunk and will shrink at a lower temperature.

FABRIC CEMENT, CF-5A

A high strength adhesive used to attach the fabric to the structure. It is also used to attach the surface tapes and reinforcement patches. From early 2004, KFA moved away from rubber based adhesive to a nitrocellulose based adhesive.

CEMENT REDUCER, CF-5B

Reducer for the cement for easier application of cement by brush or bottle, removal of glue spills from the fabric and/or reactivating of cured cement.

NITRATE FABRIC SEALER, ALSO CALLED "DOPE", CF-6A

This first fabric coating is used to create a mechanical bond between the fabric and the butyrate sealer.

BUTYRATE SEALER, CF-6C

A highly flexible and tough sealer which seals the fabric weave and acts as a base coat for the UV-Butyrate. The Butyrate is less flammable than the nitrate. During tests conducted, when the flame heat source was removed, the flame present on the butyrate extinguished.

REDUCER FOR NITRATE AND BUTYRATE

The Aeromuti nitrate and butyrate has been adapted to allow the use of normal lacquer thinners. Always use good quality 300 lacquer thinners.

UV-PROTECTION PASTE

The sun's ultraviolet radiation is polyesters' worst enemy. If left unprotected in the sun for just one year, the fabric can lose up-to 70% of its strength. To counter the sun's Ultra-violet rays, a special pigment in the form of powdered aluminium is added to the butyrate. This not only protects the fabric and gives it an indefinite life but also forms a good sanding base for final paint preparation.

PART 2: OVERVIEW OF THE COVERING SEQUENCE.

WARNING :	<p>Work in a well-ventilated area</p> <p>Breathing in solvent vapours can be harmful to your health.</p> <p>Products are highly flammable. Keep away from naked flames!</p> <p>Avoid skin and eye contact</p> <p>The wearing of thin rubber gloves is recommended.</p> <p>When applying coatings by spray equipment, observe associated safety procedures and wearing of a proper mask.</p> <p>Breathing polyurethane paint spray vapours can be fatal!</p>
------------------	---

PREPARING FOR COVERING

Place all tools, equipment and glue on a small table or trolley close to the part to be covered. Make sure that there is enough cleaning fluid (use cement reducer) in a bottle or tin to put the brushes in, when not in use. Covering has to be done in a very neat and clean manner. Ensure that your hands are clean before covering as any oil or dirt on the fabric may prevent the cement or sealer from bonding to the fabric

PREPARATION OF COMPONENTS

All surfaces in contact with fabric should be clear of any grease or oil. Wipe all steel with a rag dipped in thinners. Wooden surfaces in contact with the fabric (cap strips and nose cuff) should be degreased and lightly sanded with 800 - 1000 sandpaper.

All areas of new wood not in contact with fabric should be sealed and protected with polyurethane wood varnish. Special attention should be given to areas where water may be trapped and cause corrosion or rot. A special rubber base coating should be applied to the structure, adjacent and below a battery box for additional protection from battery acid. Control cables routed past the battery box area should also be coated. All steel should have adequate corrosion protection done and then painted with 2-pack type paint. If paint is used that is not compatible with the fabric cement, the cement will lift the paint and cause the fabric to pull loose. The best results were obtained with 2-K paint with a 30% elastic additive.

FABRIC CEMENT

The supplied fabric cement has the consistency of thick oil. At certain times during the covering process it is desirable to have a lower viscosity in order for better penetration.

The cement is reduced with the CF-5B reducer in two ratios.

The 75% cement to 25% reducer ratio is brushed onto all wood before the fabric is attached. Two to three coats are applied.

The 65% cement to 35% reducer ratio is used to cement all fabric to the structure, attach surface types and apply patches. This ratio is applied with a plastic squeeze bottle. The easiest method is to fill a large bottle with a 65/35 mix and to fill the squeeze bottle from this bottle.

WARNING :	The ratios given are guidelines. The cement should have a viscosity that allows it to easily flow into the fabric but not too thin as it will not stick properly.
------------------	---

The cement must form a mechanical bond between the polyester and the structure being covered. The cement needs to be forced into and through the fabric to achieve the best result for this bond.

The method found to give the best result is to stretch the fabric over the structure apply some cement onto the fabric over the structure and use your fingers to work the cement through the fabric onto the structure below. Do not touch a cemented area that has started to dry as the cement will stick to your fingers and create drag marks. If an area needs retouching, wet your fingers with some fabric cement and then touch the semi-dried cement.

Pre-brushing a coat of cement onto metal structures helps for a better bond. All wood must have at least 2-3 brush coats of the 65/35 mix. The brush coats seal the wood and allow for better fabric adhesion.

Fabric is usually installed span wise in sections with overlap-cemented seams at the leading and trailing edge. Seams may overlap in either direction since all seams are covered with surface tapes.

WORKING WITH FABRIC

The fact that polyester can shrink when heated to 350-F should not be interpreted to mean the fabric should be installed loosely on the airframe before heating. For the best fabric tension, remove as much slack as possible during bonding.

All polyester fabric and tapes should be protected from direct ultraviolet radiation, light, dirt, dust, water, and grease when stored over a period. Store the fabric so that it does not crease. Creases tend to stand proud on seams.

The fabric is shrunk with a good quality household iron, of minimum 1100 watt, with a thermostat capable of keeping a desired temperature within 10 °Celsius. A modelling iron is of great help, but is unfortunately quite expensive. If a steam iron is used do not fill with water.

Different heat settings are used during the covering process.

- 225°F - is used to thermo-soften the fabric cement, smooth the edges of finishing tapes and patches and remove creases.
- 250°F - is for initial tightening, smoothing wrinkles from seams and heat forming fabric around gentle radiuses.
- 350°F - is for final tightening and forming round tight radiuses.
- Never use a temperature over 250°F on seams or any cemented area as doing so could release the seam or bond.
- The fabric is at its tightest at 350° Fahrenheit, at 375°F the fabric permanently loses it's tension and will need to be replaced!

WARNING :	THE ONLY AUTHORIZED HEAT SOURCE FOR ACCURATE CONTROL OF THE TEMPERATURE TRANSFERRED TO THE FABRIC IS A CALIBRATED CLOTHING IRON, <i>NOT A HOT AIR GUN!</i>
------------------	--

The heat shrinking procedure is accomplished by moving the iron in light contact with the fabric surface at 100 - 150mm per second. Do not attempt to remove all wrinkles from one area before going to the next. The wrinkles will be removed with the next temperature setting.

The iron should be passed briefly across each panel area and excess material absorbed uniformly to avoid deforming the underlying structures. Several passes are recommended, working briefly in each area. After all wrinkles are absorbed, the opposite side or separate panel areas of the same component are tightened in the same manner.

The appearance of smoke from the fabric at 350°F iron setting indicates moisture on the filament surface is being removed as steam, and is no cause for alarm.

Note:	The fabric cannot burn through or scorch if the iron is held in one place for a period, nor will the fabric become tighter if heat is applied for longer. The amount of tension depends on temperature and not time.
-------	--

IRON CALIBRATION

The calibration of the iron is very important. Take the time and do it properly. If a power cable extension is to be used then do the calibration with the extension fitted. Use a good quality thermometer, capable of reading up to 350°F. "Aircraft spruce" sells a good glass thermometer. The COVE-RITE thermometer works well if used correctly (calibrated to room temperature).

1. Build a stack of paper towels (ñ 15 mm high).
2. If available, put a blob of heat sink on the bulb of the thermometer.
3. Place the iron on top of thermometer bulb and paper towels.
4. Advance the 'Iron's heat control until 225 °F is reached. Give the 'iron time to change temperature and the thermometer time to react.
5. Once the thermostat has switched on and off a few times and the temp has remained at 225°, mark the dial of the iron. Mark 250° and 350° Fahrenheit positions on the iron in the same manner.
6. Re-calibrate the iron if it is dropped. Recheck the temperatures every time before starting with a new section.
7. After calibration and with the iron cool, clean off all traces of heat sink.

Tip	Between ironing place the iron on the thermometer on the paper towels. This way the iron temperature can be constantly monitored.
-----	---

FINISHING TAPES AND REINFORCING PATCHES

All seams and joins must be covered with surface tape. Finishing tapes should always overlap the edge of the underlying fabric by at least 15mm. Tapes can be laid length wise or span wise.

1. Straight tapes are the trademarks of good workmanship. Long tapes should never be aligned by eye, use a chalk line. A 50mm wide tape is the minimum width of tape that should be installed over seams where two panels overlap and over areas where sharp edges below the fabric may cause chafing.
2. Tapes used to be "doped on" meaning that sealer was used to bond the tape to the fabric. The Aeromuti system requires the tapes and patches to be bonded with fabric cement. Using cement has the added benefit that if the tape edges lift, they can be "re-stuck" with an iron set at a maximum of 225°F. The tape is laid on the surface, the 65/35-ratio cement is applied on to the tapes and using finger pressure the cement is worked through the tape onto the fabric below. Any small edges or sharp corners not conforming to the final contour or

bonding to the fabric surface can be ignored temporarily. Once the tapes have dried for about 15min, the tapes and patches are smoothed with an iron at 225°F.

3. Holes for control horns, strut fittings and control cables will be reinforced with pre-shrunk fabric patches. The patch must extend a minimum of 25mm from the edge of the hole. Use a pinking scissors to cut out a patch of the appropriate size and shape. Use a soldering iron to burn any holes needed.

Good workmanship is indicated by straight and flat finishing tapes, without any notches cut into them where the tapes follow curves.

4. To pre-shrink fabric, make a frame to attach the fabric to. Shrink the fabric with an iron at 250°F. Cut all gussets and reinforcement strips from the fabric. Attach with fabric cement.

5. To get the tapes to conform to bends and curves, as on the rudder and elevator, the tape is heat formed around the bends at between 225°F and 250°F. Make an ironing board out of stiff card board. Lightly crease the tape on the centre line, cement the centre of the tape to the middle of the curved structure. Heat form the ends of the tape round the bend using the cardboard backing as shown in the sketch. Once the tape edges are flush with the fabric, apply fabric cement and work in with the fingers. For tight radiuses the iron can be set between 300° 350° F

6. Before the nitrate sealer is applied, the iron is used to smooth all the tapes and patches. Take time to ensure that all the tape and patch edges are smooth and properly cemented as it is very difficult to re-cement the tapes once the nitrate sealer has been applied.

Warning

Never iron surface tapes, at temperatures over 225°F as the tapes will shrink and curve

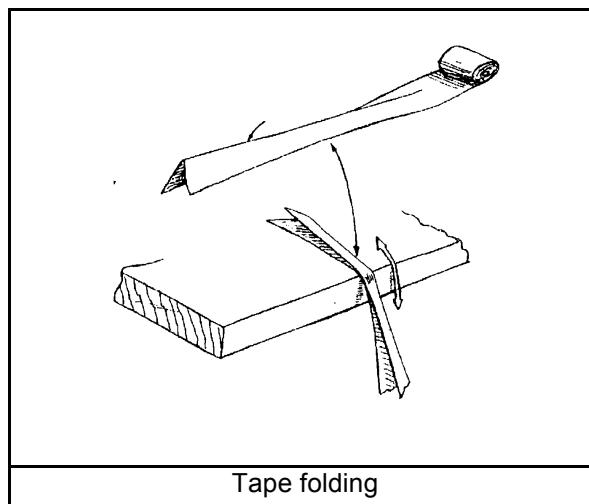

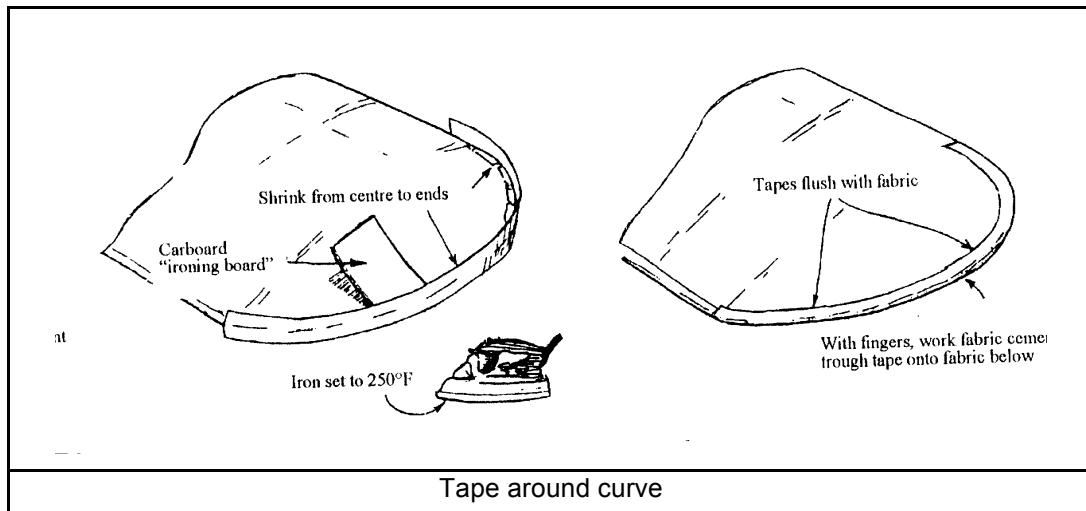

NITRATE SEALER APPLICATION

1. The nitrate sealer is used to provide a mechanical bond to the fabric and to fill the weave; it is imperative that only nitrate sealer is used on the bare polyester fabric, as butyrate sealer does not stick to polyester!

The nitrate is applied either with a brush or spray gun. For spraying and brushing, reduce the one part sealer with one part reducer. When spraying the sealer, apply 4 coats, 2 coats in each direction of the fabric weave.

2. It is very important that the first coat thoroughly penetrates the fabric to provide good adhesion. The coat should be sufficiently heavy and wet to penetrate through the fabric without dripping or running off the backside of the fabric. Dripping onto the opposite side fabric should be avoided. Remove drips from the opposite fabric surface with a rag dipped in reducer. Any runs down the fabric backside may be noticed through the final coat. Do not continue brushing after the sealer starts to dry, as it will "rope" or drag on the brush and show as a rough surface through the finish coat. First coat brush patterns will not easily show because the sealer penetrates and levels with the surface of the fabric.

3. At least one cross coats of sealer must also be applied with a spray gun after reducing 1:1. Special attention should be given to properly seal areas that touch the underlying structure (wing tanks). If the fabric is not properly sealed "pinholes" will form. The best remedy for pinholes is to lightly flat the area with 600 water paper, rinse the area with clean water and wait until completely dry. Brush sealer over the affected areas.

4. After the first sealing coat is applied, the iron cannot be used in direct contact to touch up any loose tape edges or wrinkles because it will damage the coat. If the iron must be used, use a setting of 225°F and place some aluminium foil over the surface. If the aluminium foil sticks to a fresh surface, reheat with the iron and peel off.

5. Before the next stage the nitrate will be sanded (flatted). Extreme care must be taken with sanding as you can cut through the fabric in just two passes! Be carefull of areas that have anything pressing against the fabric. Using 1000 - 800-grit water paper, carefully wet sand the sealer. After sanding, flush the surface with clean water and a soft sponge. Do not leave any sanding residue on the surface is it will prevent subsequent surfaces from sticking. Let the surface dry completely before spraying the next coat.

7. Good sanding technique requires that the microscopic high points of a coating be removed and levelled with the bottom of any pits. The sealer should be sanded to develop a smooth surface.

Note:

It is very important to flat the sealer surface properly all over to ensure a good paint grip before spraying!

BUTYRATE

1. Spray one coat of 1:1 reduced butyrate sealer, ensure that the entire fabric area is evenly covered.

UV-COAT

1. Dissolve the UV powder into some lacquer thinners. Mix 20g of UV powder per 1 litre of clear butyrate. Pour the dissolved paste into the clear butyrate and mix well.
2. Apply three cross coats of UV-butyrate thinned to 1:1. Make sure that every part of the fabric is covered. When finished the light from a 60-watt globe should be blocked.
3. Wet sand with 400 - 600 grit papers between each coat. Follow the same rules for sanding, as before. Flush and let the fabric dry completely before spraying again. Run a tack rag over the surface just before spraying sand and flush the last coat for the first paint coat.

FINAL PAINTING

1. Most amateur aircraft builders underestimate the importance of the final paint finish. The type of finish used on fabric, is the one major factor that determines the durability and service life of any fabric covering system. Any paint which is not compatible with the covering system will cause the covering to be considered un-airworthy. Furthermore the wrong paint and /or wrong application of it can ruin the eventual look and resale value of the aircraft and can add a lot of unnecessary weight.
2. The high gloss, fast drying enamels and lacquers developed for the automotive market used to paint fabric-covered aircraft become brittle and start to crack when exposed to the sun and weather within about two years. They also have limited flexibility and elasticity under impact. For the same reasons and for purposes of weight we also do not recommend clear coats over finishes on fabric.
3. The system that gives the best results is the 2-K polyurethane paint system with 30% elastic additive (sometimes called "soft face" additive).
4. Paint with no elastic additive, is brittle and will start to crack within months.
5. There are many different opinions on paint application. There are arguments for both high and low pressure spray guns, amount of spray coats, brands of paints and many more. The best is to experiment with a system and stick to what, works best.
6. Recognize at the start that there is a vast difference between a car, composite aircraft and a fabric-covered aircraft. Cars and composite aircraft have ridged surfaces with minimal flex and can be plastered with paint to obtain an ultra glossy finish. The paint on a fabric-covered plane has to be flexible, that is why we use an elastic additive, but pain will still crack if applied too thick. The thinner the paint the less chance there is of it cracking. The ideal paint coat is one that just covers the fabric and tape, but still allows the weave of the fabric to be seen. Do not try to hide the surface tapes wider layers of paint, as this defeats the object of building light and then putting on unnecessary weight, trying to get a wet look paint job. All builders that have tried to hide the tapes with paint have had their paint cracking within 1 year!

OUR PAINT SYSTEM

1. Surface preparation is the name of the game, ensure that- all tapes are properly stuck down, and that the UV-coat has been properly applied, with no pin holes and that the area has been properly flatted and cleaned.
2. Mix the paint in the following ratio
 - a) 2-K paint
 - b) Elastic additive, 30% of paint volume
 - c) Hardener, 50 % of paint & elasticizer. Follow the manufacturers ratios.
 - d) Thin about 10% of total volume, enough till right viscosity is reached.
3. Apply the first coat thinly. Wait until the coat becomes tacky. This coat is not a “soak” coat.
4. Apply a light coat over the tack mist coat. This coat will have very light colour. Wait until the coat is tacky.
5. Apply a light wet coat for fill and colour. Do not flood the surface. Do not go back to unfilled areas. Wait until tacky before spraying in missed areas.
6. Each subsequent coat paint should be applied 90 degrees to the coat under it. Overlap strokes by 50% of the fan width to provide an even application.

Warning:	Do not be tempted to spray a coat before the bottom coat is tack dry, this is only an invitation for paint runs.
-----------------	--

7. To apply trim paint, wait 4 days before flattening the area to be painted lightly with 400 grit papers. Mask the area to be sprayed and apply the trim paint in as light coats as before.

General painting tips

- a) Don't apply tape to paint that has not dried for at least 24 hours.
- b) Do not use newspaper for masking purposes. It will transfer the ink- to a fresh surface. Use only painters masking paper. Use two layers of paper to mask polycarbonate surfaces like the windshield or windows to avoid penetration of wet paint or thinner.
- c) Use special "fine line" tape to mask joints between two colours.
- d) Remove the tape when the paint is tack free.
- e) Do not use masking tape, as it tends to remove the paint.
- f) Do not spray in high humidity, direct sunlight, in the wind or in a dusty area.
- g) If unfamiliar with spray painting, hire a professional. It may be cheaper than a complete recovering job.

WARNING:	POLYURETHANE PAINT CATALYST CONTAINS POLYISOCYANIDES, READ CYANIDE. WEAR PROPER RESPIRATORS, PROTECTIVE CLOTHING AND SPRAY IN WELL VENTILATED AREAS!
-----------------	---

PART 3: GENERAL HINTS AND TIPS

LIST OF EQUIPMENT NEEDED

- Accurately, adjustable, household Iron. Minimum 110 watts
- Paintbrush 25 mm
- Small plastic bottle with a spout
- Washing pegs or bulldog clips (80)
- Table or trestles to work on
- Scissors and pinking scissors
- Box of sharp blades (Industrial safety razors)
- Bottle or tin for cleaning brushes
- Clean rag for wiping fabric off
- Soft pencils (never mark the fabric with a marking pen or ball point pen)
- Chalk line
- Heat sink

WING COVERING

1. The top surface of the wings on high wing aircraft is covered first and then the wing bottom. Low wing aircraft are just the opposite way:

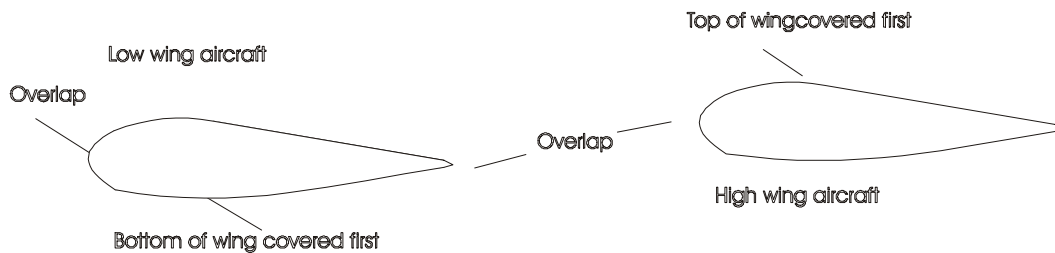

2. Rib lacing is a form of mechanically securing the fabric to the rib. The KFA wings have 25 mm wide cap strips and the fabric is cemented to the cap strips. Rib lacing or stitching is recommended for airframes fitted with engines producing more than 65 HP.

3. POLY FIBRE has an excellent book and video on covering that explains all aspects of covering including rib lacing and the various knots needed.

More detailed information about rib stitching can be found in the FAA publication AC 43.13.1B, chapter 2. This is available as a free download on the FAA publications website.

4. The shape of curved edges cause excess fabric to crease as it is smoothed and cemented. Any excess is absorbed by heat shrinking with a 250°F iron using a heavy cardboard support under the fabric. The leading and trailing edge fabric is trimmed to allow it to wrap around, a 225°F iron is used to smooth any wrinkles or fabric folds before the overlap section is cemented.

FUSELAGE AND TAIL PLANES

1. Being able to rotate the fuselage is very convenient as it reduces the work time, improves the workmanship and is useful when working alone. A simple jig can be made by bolting two wooden members on the firewall as legs to support the fuselage up and inverted. Two members are nailed horizontally across as legs to support the fuselage positioned on either side.

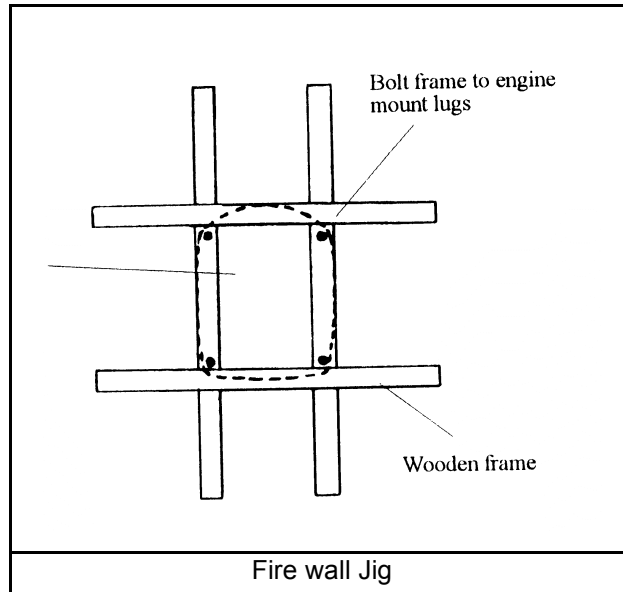

2. The bottom of the fuselage is covered first, then the sides and the top section is covered last.

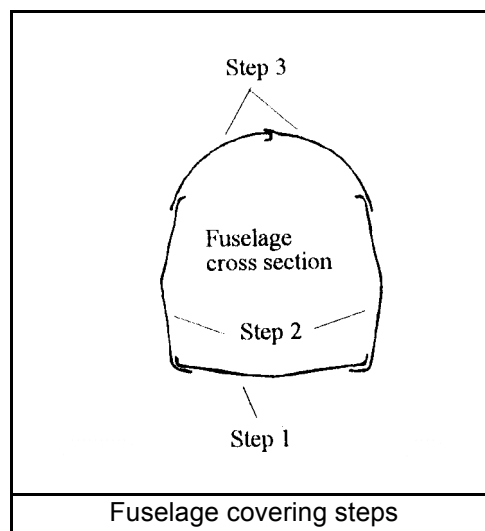

3. Surface tape should be applied to all areas on the fuselage and tail plane, where the fabric curves over the underlying structure. Surface tapes are also applied to all fabric joins.

4. The surface tape reinforces the fabric and prevents the fabric from chafing through. POLY FIBRE makes an anti chafe tape used with or instead of surface tape. The anti chafe tape (more like a polyester ribbon) has an adhesive backing on one side. The tapes work well and are highly recommended.

COVERING TIPS

1. Work as neatly as possible, clean up all cement drops and runs with a rag dipped in cement reducer
2. Go over patches and tapes with a 225°F as often as needed to get them smooth. Do not rush this step, if neglected it will have to be done later once sealed thus making it more difficult and time consuming.
3. When brushing or spraying on the sealer, make sure that the weave is completely penetrated and that every inch of the fabric is covered. Pinholes are formed when the fabric is not properly covered, they need to be sanded out and a brush coat of sealer reapplied. Do not brush over an area that is tacky as this will result in brush marks. Clean all runs inside the fabric and outside, with a cloth dipped in nitrate reducer. Remember that thin paint coat will be applied, so all cement and sealer runs will be seen. If the runs are to be covered by paint then the result is unnecessary heavy aircraft.
4. Seal all components with nitrate as soon as possible after covering. This will protect the fabric and prevent it from becoming dirty. Once sealed, if the part is dirty or dusty, blow clean with compressed air and wash with clean water.

PART 4: PRACTICE SECTION: RUDDER

The rudder is good to practice on as it has a curve in it, allowing all facets of covering to be learned. As the rudder is relatively small and only needs a small area of fabric, the cost of recovering if necessary is not too high.

1. Calibrate the iron and set at 225°F (cement smoothing and fabric folding)
2. Roll out a section of fabric on a table large enough to cover both sides of the rudder, mark and cut a section of fabric to the same contour of the rudder, allowing a 80 –100 mm overlap (ordinary scissors may be used, but pinking scissors are preferred). The fabric will be symmetrical along the hinge line. Use a soft pencil to mark the positions of the hinge tubes and rudder horns onto the fabric.

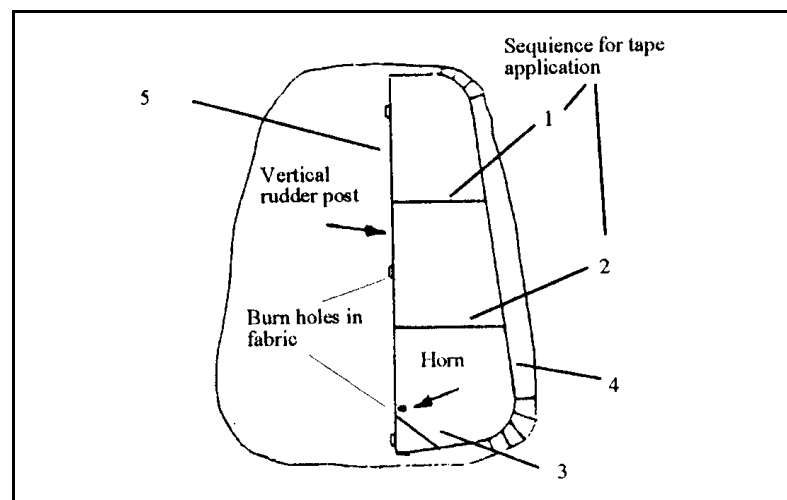

3. Cut a slot that will just allow the centre hinge tube to slip through, let the fabric lay smoothly along the vertical post, pulling the fabric as tight as possible along the hinge line, cut holes for the top and bottom hinge tubes. Fill a squeeze bottle with the 65/35-cement mixture. Run a bead of cement on the fabric along the front of the rudderpost, between the hinges. Using finger and thumb pressure work the cement trough the fabric onto the underlying structure. If an area needs more cement or reworking, wet your fingers with the cement before touching a tacky area. Once the cement has dried smooth the cemented area with an iron at 225°F and cut slots in the fabric for the rudder horns.

4. Shrink the fabric around the bottom curve with a 250°F – 300°F iron. Fold the fabric over the tube for a 180-225 degree overlap and cement the fabric to the structure, pulling the fabric as tight as possible when cementing. When the cement is dry, trim the excess material and cement the remaining edge of fabric to the tube, iron the cemented areas to remove wrinkles. Cement the rest of the fabric to the rudder. Note: forming cuts may be made in the fabric bowing around the rudder radius, but learning how to shape the fabric around curves is better.

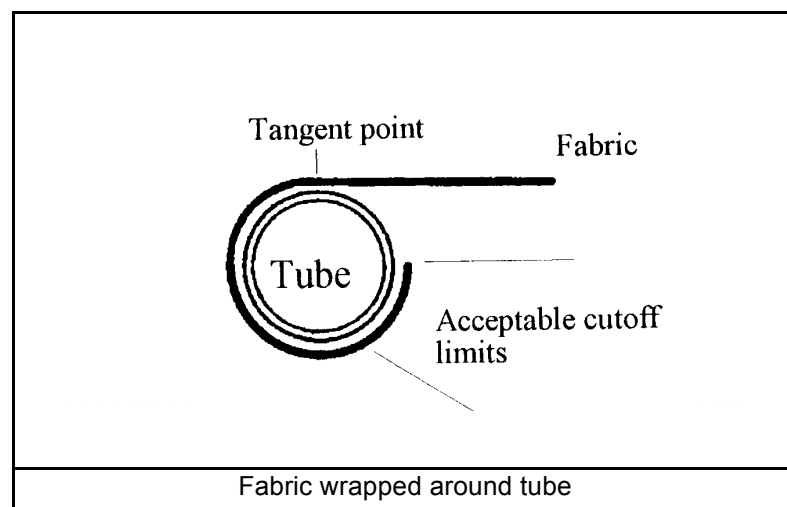

5. Heat form the fabric on the other side of the rudder, so that the fabric overlaps the bottom layer. While pulling the fabric as tight as possible, cement the fabric to the under laying fabric ensuring that there is a 10 – 15 mm overlap. Trim off all excess material with a sharp scissor and cement the fabric edge down. Iron (225°F) all the seams for a smooth finish before heat shrinking.

6. Do not attempt to shrink fabric before the cement is thoroughly dry. Use a 225°F iron to flat all the fabric edges and cemented seams, a 250°F iron may be used for stubborn creases. The secret is to get the seams as smooth as possible. Remember any imperfections will be magnified by the finishing tape and paint.

7. Using the 250°F iron, shrink the fabric symmetrically making one pass on one side then one on the other. Shrink lightly and do not concentrate the heat in one spot but move the iron slowly over the fabric. Crank up the iron to 350°F and give the final shrink. Do not be alarmed by smoke coming of the fabric this is just moisture burning off. Make several passes over the fabric to ensure that all the fabric has been shrunk

WARNING:

NEVER USE A TEMPERATURE OVER (250°F) ON CEMENTED SEAMS OR ANY CEMENTED AREA AS DOING SO COULD RELEASE THE SEAM OR BOND.

8. When dry, smooth tapes with a soldering iron, cut a hole in the centre of each patch for the rudder horn to fit through. Cement the patches over the rudder horns. The edge tapes are now applied. Crease the tape along the centre line and line up the centre line with the edge of the rudder. Cement the tape to the fabric, turn the rudder over and pulling the tape tight, cement the other half of the tape. Remember the tape must

overlap the underlying fabric edge by at least 15 mm. The tape at the curve will need to be heat formed to follow the curvature of the ruder. Cement the centre of the fabric to the centre of the rudder bow. Using the cardboard ironing board start heat forming the tape at 250°F until it lays flat with the surface of the fabric. Turn the rudder over, heat form the tape until flat with the fabric and cement.

9. When dry, smooth all tapes with a 225°F iron.

Note:

First apply the horizontal tapes and then the edge tapes (rudder post and edge).

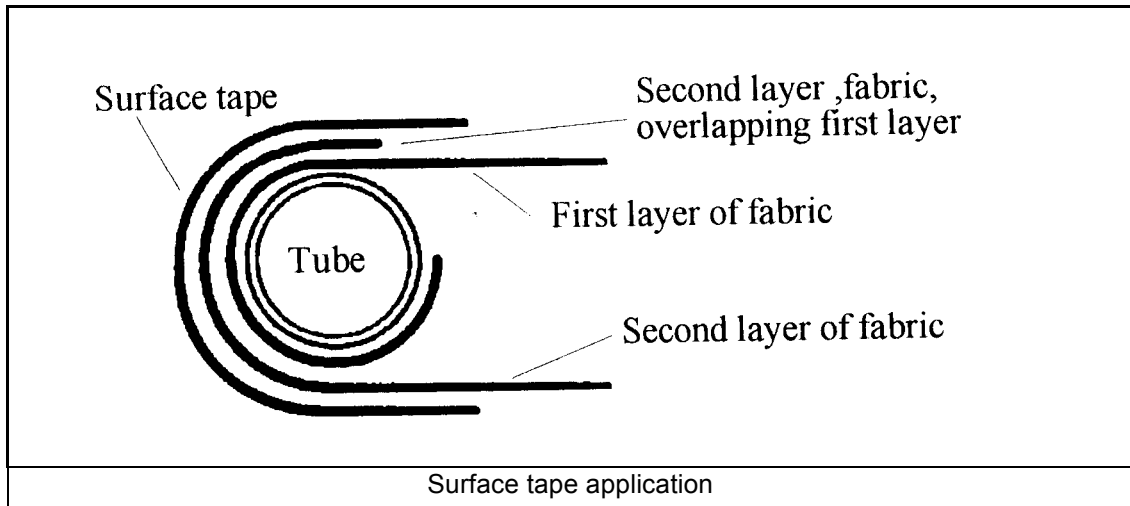

10. Once satisfied that all tapes are flat and smooth, all cement spills have been ironed smooth or cleaned up with a reducer rag, apply a coat of nitrate sealer to the fabric.

Congratulations you have just completed one of the more difficult structures, if not completely satisfied with your handy work, recover the rudder. Remember the final finish counts a lot, for if the aircraft is neatly covered and painted, the resale value of the aircraft will be so much higher.

If satisfied with the rudder, cover the stabilizer and elevator as the practise will help when covering the more difficult fuselage.